

TOOLS REQUIRED FOR INSTRUCTIONS

1. Pozi No.3 Screwdriver
2. Sharp Knife
3. Sandpaper
4. Contact Adhesive

SEAT ADJUSTMENT

Forward and Backward Adjustment

1. Remove the two screws situated either side of the cockpit rim. Whilst removing the screws, take care to hold the seat plates situated on the underside of each seat tower. Remove the plates and keep in a safe place.
2. Slide the seat into its desired position, align the slots in the seat with the holes in the shell and the holes in the back band guide. Ensure the seat is parallel to the boat.
3. Replace the two screws and seat adjustment plate either side of the cockpit rim.

Extra Padding / Height Adjustment

4. Undo the rivets on the back of the seat liner.
5. Pull the seat liner forward and pad seat.
6. Replace the seat liner and rivets.

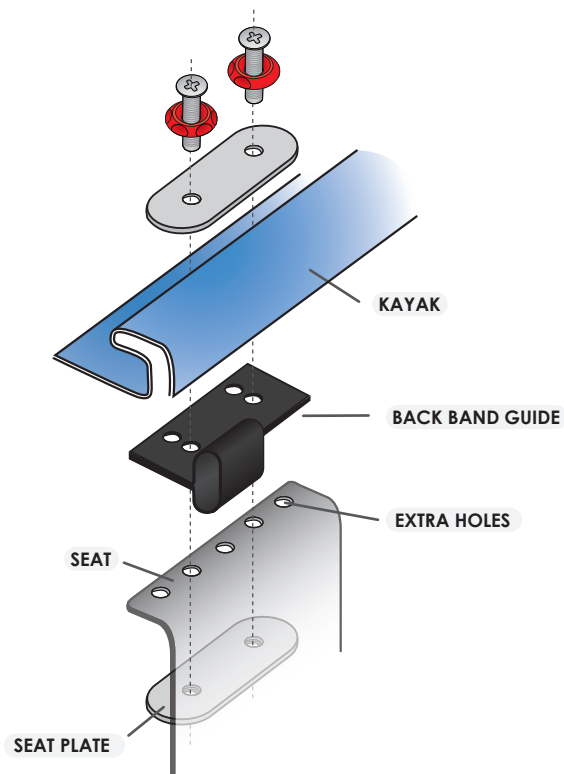
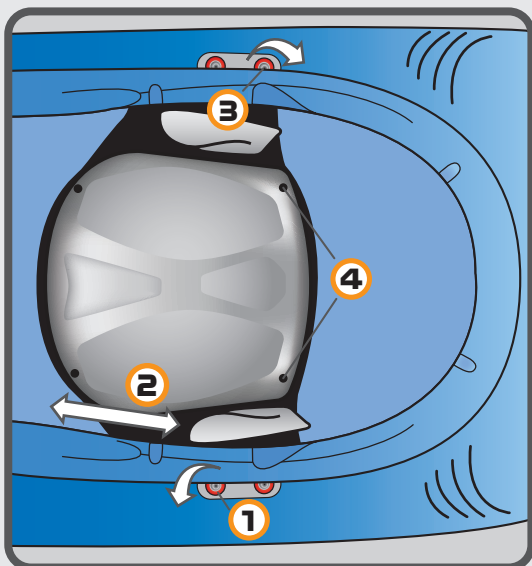

NOTE: Back band guide only fitted to left hand side of seat.



CAUTION: DO NOT USE POWER TOOLS TO TIGHTEN SCREWS, HAND TIGHTEN TO A MAXIMUM TORQUE OF 3N-m [26in. lbs.]. OVER TIGHTENING SCREWS WILL PUT COMPONENTS UNDER EXCESSIVE STRESS WHICH CAN CAUSE PREMATURE COMPONENT FAILURE AND WILL VOID THE WARRANTY.

SOME SCREWS ARE COATED WITH A LOCKING AGENT TO AVOID SCREWS BECOMING LOOSE IN TRANSIT. TO STOP COMPONENTS WORKING LOOSE AFTER ADJUSTMENT, IT IS RECOMMENDED THAT A LOCKING AGENT IS RE-APPLIED TO SCREWS. [THREADLOCK IS AVAILABLE FROM MOST HARDWARE STORES]

1. Remove the screws situated on the top of the cockpit rim and loosen the screws on the side of the cockpit rim.
2. Loosen off the back band strap by pushing the labyrinth buckle towards the front of the kayak allowing the strap to slide through while pushing the backrest gently towards the rear.
3. Slide the thigh grip to desired position ensuring the square clinch nut is located for the new position.
4. Replace and re-tighten the screws situated on the top and sides of the cockpit rim.

NOTE: To achieve the best possible fit the thigh grips should be moved as close to the paddler as comfort allows. However do not impede an easy and free exit from the boat.



CAUTION: DO NOT USE POWER TOOLS TO TIGHTEN SCREWS, HAND TIGHTEN TO A MAXIMUM TORQUE OF 3N-m [26in. lbs.]. OVER TIGHTENING SCREWS WILL PUT COMPONENTS UNDER EXCESSIVE STRESS WHICH CAN CAUSE PREMATURE COMPONENT FAILURE AND WILL VOID THE WARRANTY.

THIGH GRIP ADJUSTMENT

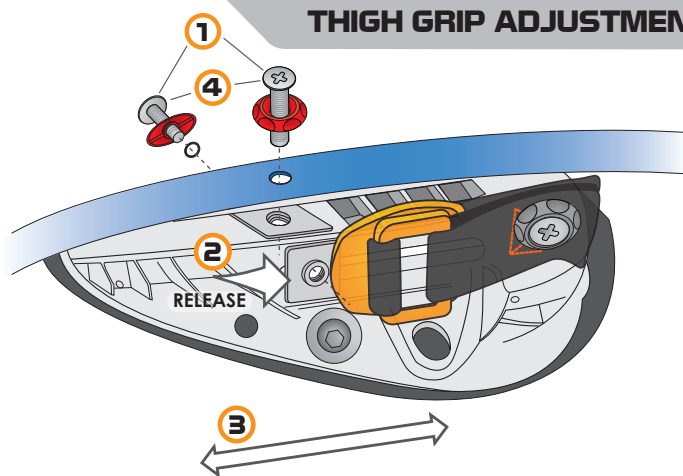

NOTE: Buckle only on left hand thigh grip

SOME SCREWS ARE COATED WITH A LOCKING AGENT TO AVOID SCREWS BECOMING LOOSE IN TRANSIT. TO STOP COMPONENTS WORKING LOOSE AFTER ADJUSTMENT, IT IS RECOMMENDED THAT A LOCKING AGENT IS RE-APPLIED TO SCREWS. [THREADLOCK IS AVAILABLE FROM MOST HARDWARE STORES]



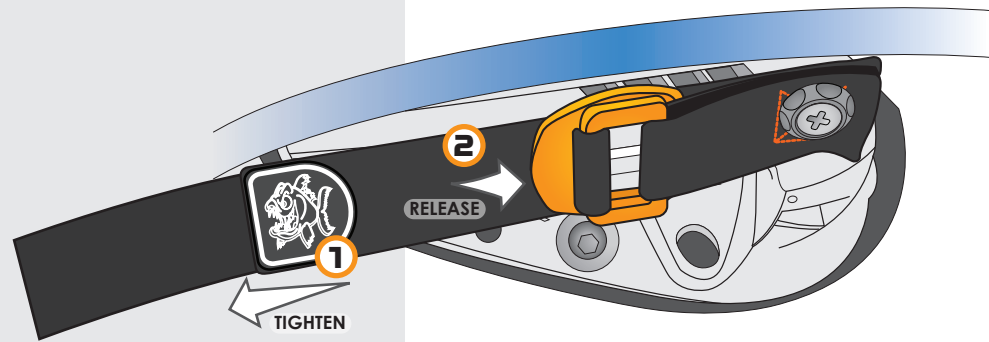

NOTE: Buckle only on left hand thigh grip

The Rapid+ back band can be fully adjusted forwards and backwards to provide greater comfort and performance by means of a simple webbing strap system.

Forward and Backward Motion

1. Whilst sitting in the boat – pull webbing through the labyrinth buckle situated on the left thigh grip until the back band is supporting you firmly.
2. Release the back band by pushing the labyrinth buckle away from you to release the webbing whilst slightly easing the pressure on the back band.



WARNING: OVER TIGHTENING THE BACK BAND MAY IMPEDE AN EASY AND FREE EXIT FROM THE BOAT. IT MAY ALSO PUT COMPONENTS UNDER EXCESSIVE STRESS WHICH CAN CAUSE PREMATURE COMPONENT FAILURE.

HIP PAD ADJUSTMENT

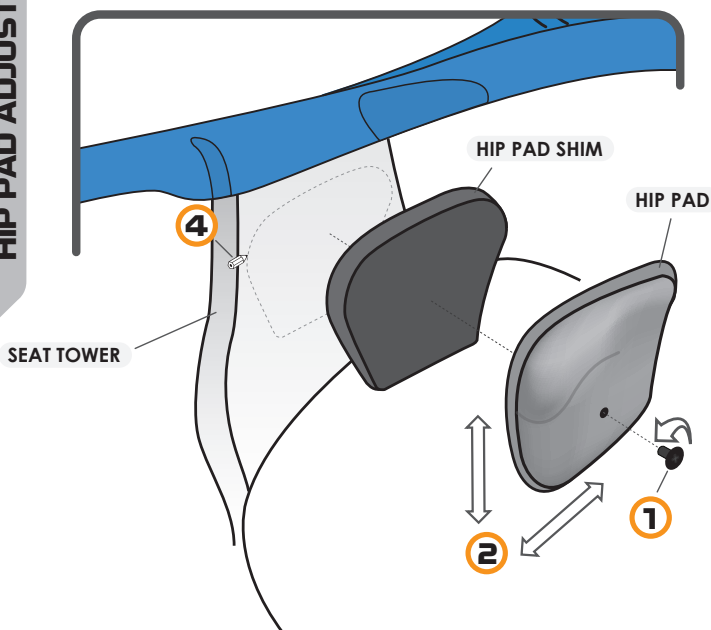

CAUTION: ONCE STUCK YOU WILL NOT BE ABLE TO REPLACE OR MOVE THE HIP PAD, TAKE YOUR TIME AND GET IT RIGHT!

The Rapid+ Hip Pads can be attached in the desired position by means of the self adhesive backing and shims provided.

1. With a screwdriver remove the screw rivets holding the hip pads in the shipped position.
2. Sit in the kayak with your normal kayaking gear on and place the hip pads in the required position.

NOTE: Do not yet remove the backing paper.

3. If shims are required to make the fit more snug remove the backing paper from the hip pads and stick in place with the shim adhesive side away from the hip pad.

NOTE: The hip pads should be in contact with your hips so that you can control the kayak properly however they should not be so tight as to cause any discomfort or to impede easy entry and exit.

4. When the required position is found mark it with a pencil and get out of the kayak.
5. Peel off the backing paper and carefully place the hip pad in the desired position.

FULL PLATE FOOT RESTS

FOR SHORTER PADDLERS
USE THE LARGER POD

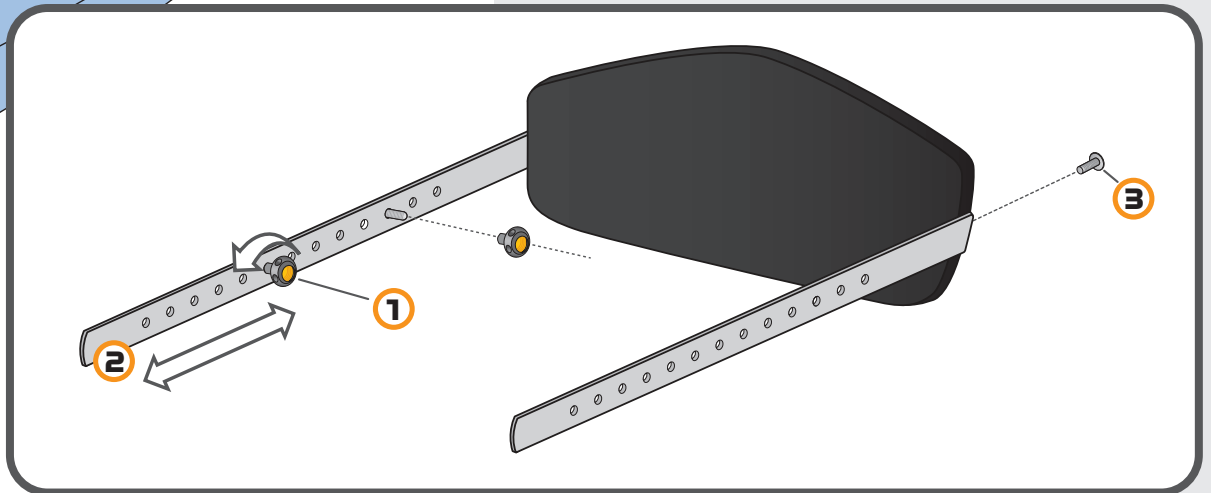
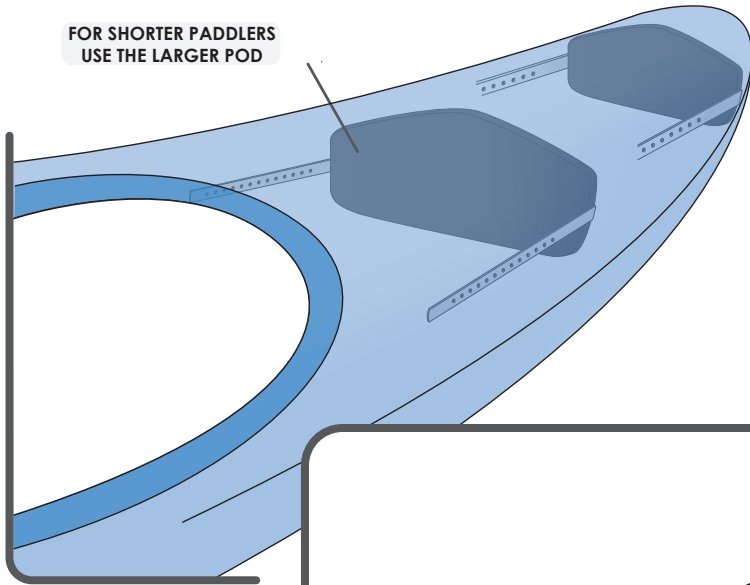

Creek Boats Only

1. Remove the four thumb screws situated on the foot rest bars in the bow of the kayak.
2. Move the foot rest into the desired position and replace the four thumb wheels. [Tighten hand tight only].
3. Should the foot rest not cover the majority of the gap in the bow of the kayak it may be necessary to replace the foot pod with the other pod supplied. To do this simply remove the footrest from the kayak and remove the screws, hold the bars in place then remove the bars from the pod. Swap the pod and replace the bars and screws, then replace the footrest into the kayak. The small pod is fitted as factory standard.

NOTE: We suggest to avoid injury / entrapment that the foot pod and any gap surrounding the foot pod be padded / or plugged with foam [supplied].



CAUTION: DO NOT USE POWER TOOLS TO TIGHTEN SCREWS, HAND TIGHTEN TO A MAXIMUM TORQUE OF 3N-m [26in. lbs.]. OVER TIGHTENING SCREWS WILL PUT COMPONENTS UNDER EXCESSIVE STRESS WHICH CAN CAUSE PREMATURE COMPONENT FAILURE AND WILL VOID THE WARRANTY. SOME SCREWS ARE COATED WITH A LOCKING AGENT TO AVOID SCREWS BECOMING LOOSE IN TRANSIT. TO STOP COMPONENTS

WORKING LOOSE AFTER ADJUSTMENT, IT IS RECOMMENDED THAT A LOCKING AGENT IS RE-APPLIED TO SCREWS [THREADLOCK IS AVAILABLE FROM MOST HARDWARE STORES]

CAUTION: DO NOT CUT FOAM IN BOAT. ONLY REMOVE THE SELF ADHESIVE BACKING FROM FOAM PADDING ONCE THE DESIRED FITTING HAS BEEN ACHIEVED.

SHOC BLOC FOOT RESTS

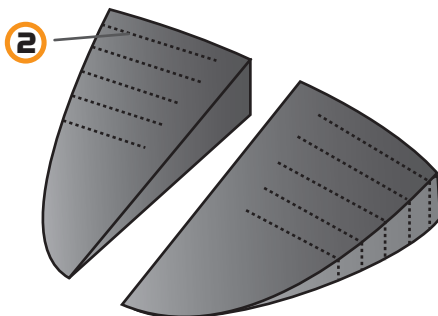
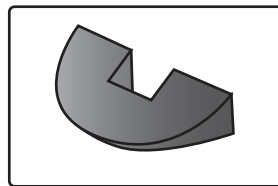

River / Play Boats Only

1. Remove the foam wedge from the kit bag.
2. To adjust the foot rest position, Place the footrest into the bow of the kayak. If the foot room is too tight remove the footrest and cut off one marking from the widest end of the foam wedge. Repeat until desired fit is accomplished.

NOTE: Pyranha recommend that the foam shoc block is glued into the kayak with contact adhesive [Not Supplied with kayak] available from your local dealer or hardware store.

NOTE: Pyranha recommend that the foam shoc block is a little larger than required as the foam will compress slightly over time.

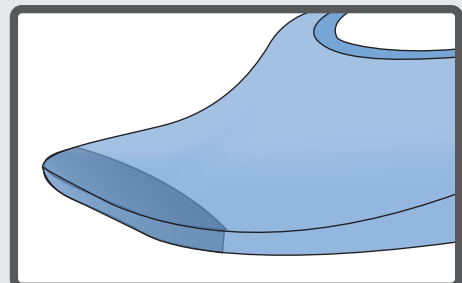

CAUTION: ONLY REMOVE THE SELF ADHESIVE BACKING FROM FOAM PADDING ONCE THE DESIRED FITTING HAS BEEN ACHIEVED.

pyranha®

AIR BAGS

To prevent the air bags popping out when submerged in the water, it is recommended that they are attached to the boat using cable ties on the gear loops.

BOLTS AND WASHERS

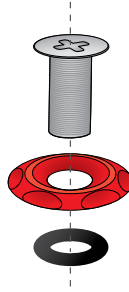

All external bolts are fitted with custom washers and O-rings. If you are experiencing leakage or need to tighten / replace any screws ensure that the O-ring is seated correctly prior to tightening screws.



CAUTION: DO NOT USE POWER TOOLS TO TIGHTEN SCREWS, HAND TIGHTEN TO A MAXIMUM TORQUE OF 3N-m [26in. lbs.]. OVER TIGHTENING SCREWS WILL PUT COMPONENTS UNDER EXCESSIVE STRESS WHICH CAN CAUSE PREMATURE COMPONENT FAILURE AND WILL VOID THE WARRANTY. SOME SCREWS ARE COATED WITH A LOCKING AGENT TO AVOID SCREWS BECOMING LOOSE IN TRANSIT. TO STOP COMPONENTS WORKING LOOSE AFTER ADJUSTMENT, IT IS RECOMMENDED THAT A LOCKING AGENT IS RE-APPLIED TO SCREWS [THREADLOCK IS AVAILABLE FROM MOST HARDWARE STORES]



WARNING: REMOVE ALL PACKAGING MATERIAL FROM THE CANOE / KAYAK [ENSURE THAT THE WHITE POLYSTYRENE BLOCKS IF FITTED BETWEEN THE DECK AND HULL JUST IN FRONT OF THE COCKPIT HAVE BEEN REMOVED]. TAKE CARE NOT TO DAMAGE OR SCRATCH THE CANOE / KAYAK IF USING A SHARP INSTRUMENT / KNIFE TO REMOVE PACKAGING

WARNING: AFTER MAKING ANY ADJUSTMENTS AND BEFORE USING THE CANOE / KAYAK, ENSURE THAT ALL USERS OF THE CANOE / KAYAK CAN EASILY AND FREELY EXIT FROM THE BOAT. DO NOT ADJUST THE FITTINGS, MODIFY YOUR SEAT OR THIGH GRIPS IN ANY WAY THAT MAY REDUCE YOUR ABILITY TO EXIT FROM YOUR BOAT.

